



9/7/2017

Specification

	SI	RF-SJ102L2H- 063N06D	RF-SJ102L2H- 063N061	RF-SJ101L4H- 063H04D
Total Heat of Rejection	kW	32,0	32,0	32,0
Ambient Temperature	°C	30,0	30,0	30,0
Condensing Temperature	°C	39,9	39,9	41,6
Actual TD	K	9,9	9,9	11,6
Dew or Mid Point		Mid Point	Mid Point	Mid Point
Refrigerant		R449A	R449A	R449A
Hot Gas Inlet Temperature	°C	80,0	80,0	80,0
Maximum Allowable Pressure	barg	32	32	32
Maximum Medium Temperature	°C	120	120	120
PED Category		1	1	1
Sound Pressure Level	dB(A)	43 @ 10 m	42 @ 10 m	55 @ 10 m
Mean Sound Pressure Level	dB(A)	45 @ 10 m	44 @ 10 m	57 @ 10 m
Sound Power Level	dB(A)	76	76	88
Sound Spectrum 125 Hz	dB	78	75	90
Sound Spectrum 250 Hz	dB	76	76	89
Sound Spectrum 500 Hz	dB	72	71	85
Sound Spectrum 1 kHz	dB	73	73	83
Sound Spectrum 2 kHz	dB	68	68	80
Sound Spectrum 4 kHz	dB	62	62	75
Sound Spectrum 8 kHz	dB	55	55	67
Tube/Fin Material		CU/AM	CU/AM	CU/AM
Surface Area	m2	62	62	62
Subcooling Section		No	No	No
Degrees of Subcooling	K			
Connections		Same End	Same End	Same End
Inlet Connection Size	OD	1-3/8"	1-3/8"	1-1/8"
Outlet Connection Size	OD	1-1/8"	1-1/8"	7/8"
Subcooling Connections				
Subcooling Inlet Connection	OD			
Subcooling Outlet Connection	OD			
Orientation		Horizontal	Horizontal	Horizontal
Air Discharge Direction		Vertical	Vertical	Vertical
Refrigerant Charge	kg	4,0	4,0	3,4
Altitude	m	0	0	0
Air Volume	m3/s	4,5	4,5	2,8
Internal Volume	dm3	12	12	11
Input Power (Total)	kW	1,06	1,05	1,95
Energy Rating		D	D	E
Fan Speed	1/min	890	880	1310
Control Voltage (for EC fans)	V	0	0	0
Electrical Supply		400-3-50	230-1-50	400-3-50
Rows of Fans		1	1	1
Fans per Row		2	2	1
Starting Current (per fan)	A	4	4,8	14
Full Load Current (per fan)	A	1,2	2,8	3,4
Overall Length	mm	2232	2232	1232
Overall Width	mm	828	828	828
Overall Height	mm	970	970	970
Dry Weight	kg	90	90	92
Part Number		RF-SJ102L2H-063N06D-AM	RF-SJ102L2H-063N061-AM	RF-SJ101L4H-063H04D-AM
Software Release		3.9.0	3.9.0	3.9.0

Kelvion Searle

20 Davis Way, Newgate Lane, Fareham, PO14 1AR, United Kingdom  
A trading division of Kelvion Ltd

# RF-SJ - Refrigeration Flatbed

**General information** - The RF-SJ - Refrigeration Flatbed is part of the RF range. Developed to replace the popular ME condenser this product has been optimised for the capacity range between the MSA and the larger RF condenser. The RF-SJ reflects features from both product ranges, such as profiled side plates and versatile leg arrangements and is available as a Dry cooler and Gas cooler. The highly efficient EL-Fin has been configured for the condensers and dry coolers within the range to achieve optimised thermal performance within a given footprint. Selection can be performed by using our selection software which can be downloaded from our website.

**Capacities** - 9 - 165kW

Fin material	Description
CU/AL	Copper tube/Aluminium fin
CU/AV	Copper tube/Epoxy coated Aluminium fin
CU/BG	Copper tube/Aluminium fin Blygold coated
CU/MB	Copper tube/Aluminium Magnesium fin Blygold coated
CU/AM	Copper tube/Aluminium Magnesium fin standard
CU/CU	Copper tube/Copper fin
CU/ET	Copper tube/Copper fin Electro tinned

**Coil** - The RF-SJ range utilises the EL-Fin configuration for most applications. Standard EL (12FPI) incorporates  $\frac{3}{8}$ "(9.5mm) tube diameter on an equilateral spacing achieving a good balance of reduced refrigerant charge whilst maintaining appropriate thermal load to achieve good system stability. The coil is fully supported, through its length and depth, by tube sheets and internal fan baffles secured to the continuous one piece side plates. The coil tubes are also supported on Aluminium or Copper insert plates secured to the tube sheets and fan baffles.

**Casework** - The casework is designed to maximise strength whilst reducing the number of components. Each side plate is cold formed from a single piece of pre-galvanised sheet steel and powder coated RAL7032 (Pebble Grey) on the outside. The legs can be removed to enable easy stocking and delivery.

Options	Description
AC Fan Control	Direct mount, phase cut AC control option (Triac)
EC Fan Control	Low cost and easy to use 0-10V EC control
Isolators	Fan Isolators
Alternative Fin Materials	Epoxy coated aluminium, copper, Blygold, electro-tinned
Sub-Cooling	Built in sub-cooling upon request
Model option	LF-SJ or OF-SJ all available in these sizes

**Fans** - We offer either AC or EC fans supplied by EBM Papst available in a 630mm diameter with a choice of 4, 6, 8 pole.



**Controls** - Basic options on these ranges are:

- AC Control - Direct mount, phase cut AC control option (Triac)
- EC Control - Competitive and easy to use 0-10V EC control

All the above options are available with fan mounted isolators

**Features**

- Eurovent approved performance tested to EN 327 and EN13487
- Manufactured to Quality Standard ISO9001:2008
- Profiled side channel for increased strength
- Galvanised steel case and legs
- Standard fin spacing 2.1mm
- Powder coated RAL 7032 grey
- Standard Copper (CU) tube, Aluminium-Magnesium (ALMG) fins
- Copper inlet and outlet headers
- Pressure tested and sealed
- AC and EC fans offered as standard
- 'Pallet' sized units to optimise customers storage space
- Units stacked to reduce transport costs
- Minimal unit size options to enable easy stocking and delivery

**Certification** - RF-SJ models are "Eurovent Certify All" certified. Searle is a quality assured company to ISO 9001: encompassing Performance Testing, Manufacturing Systems and Inspection Procedures. Searle's products are also CE marked.

**Selection software** - Selection and pricing can be performed on the Searle Selection software which can be downloaded from our website.



## Dimension drawings

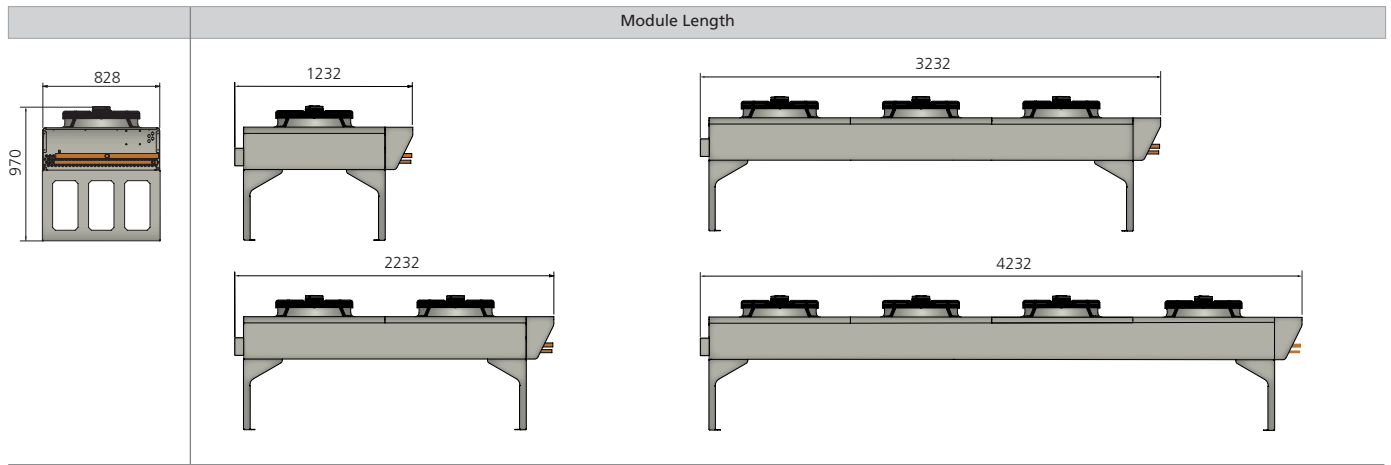

## Nomenclature

**R F - S J 1 01 L 2 H - 063 N 04 D**

Product series:	R = Refrigerant	↑
Unit form:	F = Flatbed	↑
Module width:	S = Nominal	↑
Module length:	J = 1000mm	↑
Fan rows:	1	↑
Fans per row:	1 - 4	↑
Fin type:	EL = $\frac{3}{8}$ " (9.5mm) tube, G = Gas cooler	↑
Coil rows:	2, 3, 4, 5, 6	↑
Orientation:	H = Horizontal, V = Vertical	↑
Fan Diameter:	063 = 630mm	↑
Fan type:	N = AC Normal, H = AC high power, M = EC high power, L = EC low power	↑
Motor pole:	04, 06, 08	↑
Motor wiring:	Delta, Star	↑

